

Product Sheet

Item No. S A P A Q S 0 075 P 2 T 2 L 0 N

housing / data

housing type	swivel castor
series	apparatus
fixing type	fixing plate
hole dimensions / hub width	60 x 60 mm / 28 mm
thickness of fixing / fork	1.80 mm / 1.50 mm
surface treatment	stainless steel



wheel / data

diameter	75 mm
wheel center	Polypropylene grey
wheel tread	thermopl. rubber 95° Shore A grey
bearing	plain bearing (stainless steel)
threadguard	no separate threadguard
hub width	28 mm
axle diameter	M 6
temperature range	-20°C - +60°C
dyn. load capacity	75 kg
test norm	DIN: EN 12532

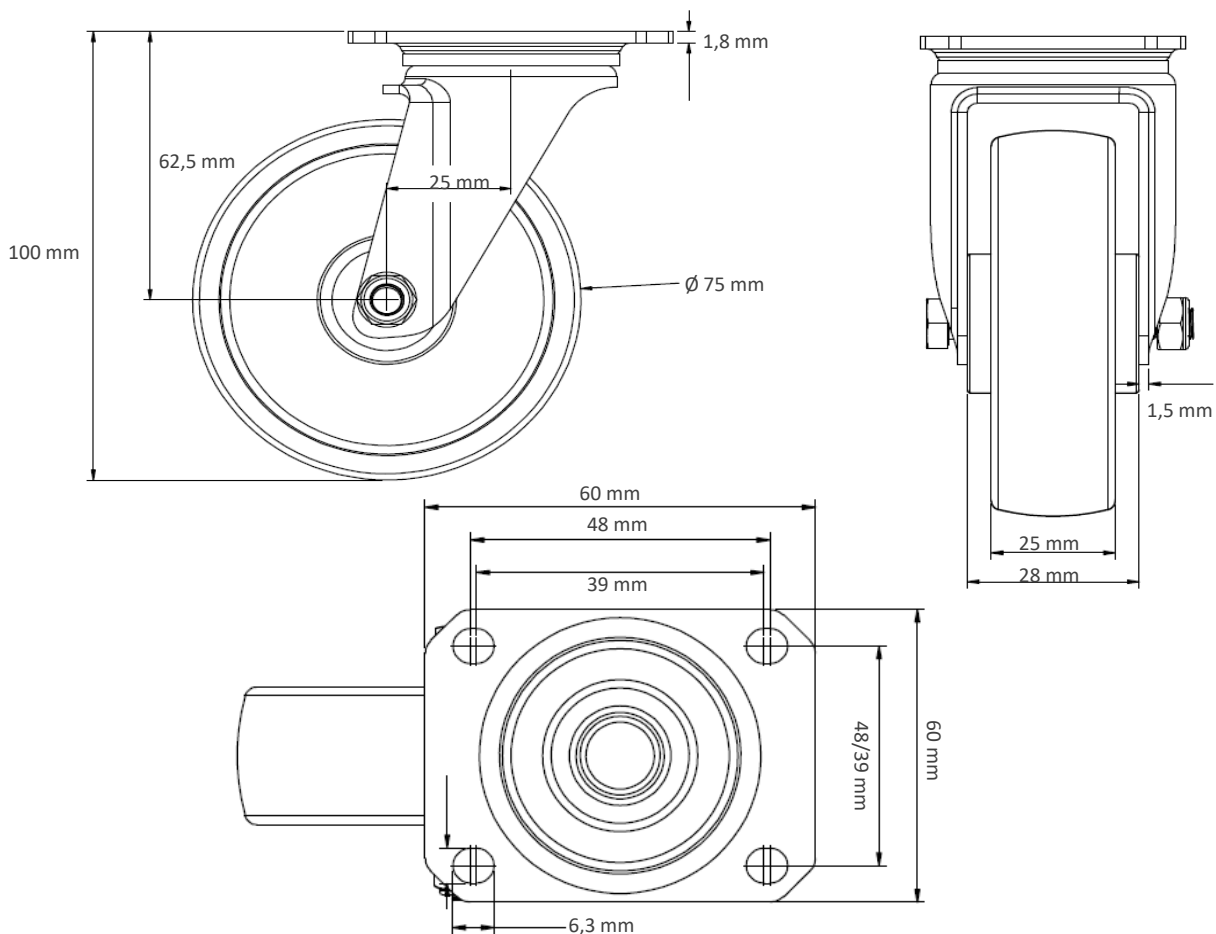
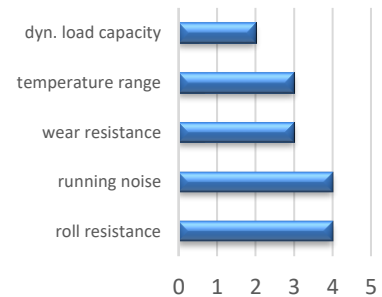

Deviation possible! All information is subject to change.